

## *Original Paper*

# A Study on the Connotation and Measurement of Internet Celebrity Leadership

Yunli He<sup>1\*</sup>

<sup>1</sup> Guangxi Normal University of Economics and Management, Guilin, Guangxi, China

\* Corresponding Author: E-mail: 2818805646@qq.com

Received: January 26, 2026

Accepted: March 22, 2026

Online Published: April 14, 2026

doi:10.22158/ibes.v8n2p138

URL: <http://dx.doi.org/10.22158/ibes.v8n2p138>

### ***Abstract***

*Internet celebrities exert a significant influence on the values and behaviors of the general public, demonstrating strong leadership. However, there is a lack of research on internet celebrity leadership at present. To gain an in-depth understanding of internet celebrity leadership, this study adopts both qualitative and quantitative methods to investigate the connotation, dimensions and measurement of internet celebrity leadership based on the CPM leadership theory. Internet celebrity leadership is a new type of leadership derived from the general connotation and characteristics of leadership as well as the functional requirements of internet celebrities, which includes character and morals leadership, performance achievement leadership and maintenance leadership. The scale consists of three dimensions, namely personal morality, performance achievement and group maintenance, with a total of 20 items, and presents satisfactory reliability, convergent validity, discriminant validity and model fit.*

### ***Keywords***

*internet celebrities, leadership, CPM leadership theory*

## **1. Introduction**

The rapid development of the mobile internet has given rise to diverse characteristics of the era, such as the fan era, the entertainment era, and the commercial era. The integration of internet celebrities and social platforms has enabled internet celebrities to rapidly amass enormous fan bases on social platforms and thus occupy a dominant position in online discourse. From online creators influencing the social economy and public awareness through high-quality content production, to internet celebrity officials boosting the development of local industrial economies via short videos and live streaming, and to entrepreneur-influencers exerting impacts on the public at the social and cultural level through

their personal charisma, this indicates that the public influence and practical effects of internet celebrities have spread not only online but also extended from the virtual world to real life. Obviously, amid the fragmented communication of social networks and self-media, internet celebrities have demonstrated leadership that cannot be ignored, exerting a profound influence on the general public and society as a whole. Therefore, in view of the changes in leadership styles in the new internet era, conducting in-depth research on internet celebrity leadership is necessary not only for internet celebrities to adapt to the trend of the times and accelerate the transformation of leadership concepts but also for improving their professional capabilities as well as for the progress of social development, which bears important theoretical and practical significance for promoting the development of internet celebrities themselves and society at large.

## 2. Literature Review

Through reviewing existing literature, it is found that studies explicitly referring to “internet celebrity leadership” are relatively scarce. Relevant research mainly focuses on the celebrity effect and influencer impact, among others. Li Liwen argues that the celebrity effect primarily refers to an ability whereby actors in cyberspace exert influence on online audiences and sustain their continuous attention by virtue of personal qualities, talent, expertise, morality, emotion and other factors [1]. Al-Emadi et al. elaborated opinion leadership among influencers on visual social media platforms, identifying credibility, storytelling and content quality, platform congruence, homogeneity between actual and desired images, and consistency as the five major factors contributing to leadership on visual social media platforms [2]. However, in-depth literature analysis reveals that numerous scholars have generally implied an emphasis on internet celebrity leadership in their discussions of the internet celebrity phenomenon. Specifically, these studies highlight how internet celebrities employ their strong influence and online social connections to guide and shape public attitudes, consumption behaviors and social trends. With regard to shaping public attitudes, differences in internet celebrities’ information content, communication approaches and presentation styles lead to distinct effects on netizens’ values [3]; internet celebrities’ own values are more easily transmitted to their audiences [4], thereby influencing public perceptions, viewpoints and emotional values at both individual and societal levels [5]. Concerning the guidance of public consumption behavior, relevant studies have analyzed changes in consumers’ purchase intention and consumption behavior in the context of celebrity endorsement [6], and further examined the impacts of influencer traits on consumer purchasing decisions, including credibility, expertise and attractiveness [7]. Fan Zengmin et al. contend that internet celebrities share and promote products on online platforms through texts, images, short videos, live streaming and other formats, thus encouraging fans to make purchases and conduct secondary promotion [8]. In terms of steering social trends, research by Liu Tingting et al. indicates that against the backdrop of rednote as a fashion infrastructure, contemporary fashion perceptions in China are evolving toward popularization, refinement and internet-oriented development, with an increasingly diverse group of participants in

fashion consumption that is no longer confined to a specific social class [9].

Research on internet celebrity leadership has covered various aspects, such as leadership in influencing public attitudes, leadership in guiding consumption, and leadership in directing social trends, which provides a multidimensional perspective for understanding internet celebrity leadership. Nevertheless, existing research also suffers from several limitations: first, in terms of research content, most studies focus on the modes of internet celebrity leadership and their outcomes, as well as empirical research on internet celebrities' effects on consumers, yet there is little in-depth interpretation and definition of the concept of internet celebrity leadership itself; second, regarding conceptualization, the available literature adopts one-sided definitions or descriptions from only a single aspect, clearly lacking a comprehensive and integrated framework to define its connotation; third, in terms of measurement instruments, current measurement studies related to internet celebrities are mostly concentrated in the field of consumer leadership, and researchers have not attempted to develop or apply a multidimensional measurement instrument that can comprehensively assess internet celebrity leadership. Viewed from the above, theoretical research remains insufficient with respect to the intrinsic nature, dimensions, and quantitative evaluation methods of internet celebrity leadership, making it difficult to provide effective guidance for internet celebrity leadership practices. Accordingly, this study adopts an integrated approach of qualitative and quantitative research. First, it conducts an in-depth exploration of the connotation of internet celebrity leadership from the academic logic of leadership theory and the historical logic of the functional requirements of internet celebrities; second, it analyzes the structural dimensions of internet celebrity leadership to enrich the understanding of the construct; finally, combining structural elements and drawing on relevant measurement studies of leadership and internet celebrity traits, this study attempts to construct a scientific and comprehensive measurement model for internet celebrity leadership, so as to provide an instrumental foundation for subsequent relevant empirical research and offer references and guidance for internet celebrities to enhance their leadership.

### **3. Analysis of the Connotation of Internet Celebrity Leadership**

Analyzing the connotation of internet celebrity leadership, which constitutes an answer to the fundamental question of “what internet celebrity leadership is”, serves as the starting point for conducting research on and implementing practices of internet celebrity leadership. From the perspective of conceptual composition, “internet celebrity leadership” can be decomposed into two components: “internet celebrity” and “leadership”; accordingly, research on the connotation of internet celebrity leadership requires an in-depth exploration of the universal connotative characteristics of leadership, a systematic review of the functional development of internet celebrities, and an investigation into the connotation of internet celebrity leadership.

#### *3.1 Connotation and Characteristics of Leadership*

Leadership constitutes a critical element in all leadership relationships, which has accordingly given

rise to a substantial body of spontaneous discourse on leadership, refining and deepening people's understanding of leadership from diverse perspectives. Based on a literature review, the definitions of leadership can generally be categorized into the following strands. First, the influence perspective, which views leadership as the influence exerted by leaders over followers toward organizational goals, vision, and change [10], emphasizing that the essence of leadership is influence [11]. Second, the ability perspective, which defines leadership as the capacity to endow an organization with vision and translate that vision into reality [12], as well as the ability to motivate followers to exert voluntary effort and achieve excellence [13]. Third, the process perspective, which regards leadership as the process by which leaders exert influence on followers to accomplish objectives [14]. Fourth, the relationship perspective, which conceptualizes leadership as the reciprocal influence relationship between leaders and followers [15]. Fifth, the integrated force perspective, which holds that leadership represents a combination of various forces in leadership activities, including influence, capability, and positional power [16][17].

From the developmental trajectory of leadership connotation, existing research increasingly emphasizes the systematic and relational nature of leadership, which is specifically reflected in the following aspects. First, leadership is an interactive process between individuals; as a relational construct, it transcends simple command and obedience, encompassing multiple dimensions such as trust, respect, motivation, and influence. Second, leadership is context-dependent, involving interactions among multiple dimensions including individual traits, team dynamics, organizational culture, and external environment. Third, both formal and informal conditions jointly shape the intensity and functioning of leadership, among which the informal attributes of leaders serve as a key criterion for measuring their influence on followers. Fourth, leadership is a dynamic force mobilized to achieve diverse goals, which extend beyond the shared vision between leaders and followers to broader domains of society, culture, environment, and individual development.

Among the multitude of leadership theories, the CPM leadership theory proposed by Ling Wenquan provides a more comprehensive account of leadership behavior; it is an integrated leadership theory that effectively combines behavioral theory and trait theory, and has also been verified to be more consistent with the Chinese cultural context [18]. The CPM leadership theory comprises three factors: Factor C (character and morals), Factor P (performance), and Factor M (maintenance). Specifically, Factor C pertains to the self, Factor P to work, and Factor M to others, with the three factors being interdependent and mutually reinforcing. A leader can exert effective leadership only by properly managing relationships with work, others, and the self [10]. Further empirical research has revealed that Factor C exerts the strongest impact on subordinates' behavioral attitudes, and also functions as an enhancing moderator in the mechanisms of Factor P and Factor M, suggesting that leadership represents a comprehensive manifestation of leaders' capabilities in character, performance, and maintenance [19].

### *3.2 Functional Positioning of Internet Celebrities*

Internet celebrities represent a new type of celebrity in contemporary society. In 2006, internet users described internet celebrities as individuals who gained fame online [20]; on this basis, internet celebrities have been regarded as a group that accumulates personal influence through the internet and receives extensive admiration from netizens in specific fields [21], and mainly refers to netizens who quickly gained popularity online and attracted a large number of followers due to their unique ideas or behaviors [22]. One of the characteristics of this group is that they become well-known to the public by relying on online platforms. By continuously delivering products, knowledge, ideas, values or life attitudes through the internet, internet celebrities exert sustained influence on their audiences, and their functional requirements are therefore inevitably highly consistent with the needs of promoting the development of the network society. Internet celebrities have played a vital role in boosting social economy, promoting spiritual culture, leading fashion trends, and advancing the process of democratization. The state requires internet celebrities to possess extensive knowledge background, outstanding talents, distinctive personalities, valuable personal charisma, positive values and remarkable sense of social responsibility [23]. In the new era of internet development, internet celebrities should strengthen political guidance, integrate public discourse, innovate communication discourse, and promote the prevention and control of ideological security risks in cyberspace [24]. In practice, the exertion of internet celebrities' leading functions relies on their ability to guide public opinion, disseminate content and forms, and interact with audiences [25]. Being closely connected with the general public, internet celebrities should demonstrate leadership in ensuring and advancing the diversified harmony, standardization and orderly construction of the internet.

### *3.3 Connotation of Internet Celebrity Leadership*

A review of existing literature reveals that relevant descriptions of internet celebrity leadership share four common characteristics: first, the connotation is mainly centered on influence and capability; second, the extension unfolds around the activities of internet celebrities; third, it is directed toward goals and visions; fourth, its sources include both "formal conditions" and "informal conditions", with greater emphasis on the latter. Accordingly, based on existing research on internet celebrity leadership, in line with universal definitional research on the connotation of "leadership" and the CPM leadership theory that fits the unique cultural context of China, and combined with the functional development requirements of "internet celebrities", this study defines internet celebrity leadership as "the ability of internet celebrities to leverage their distinctive traits to lead, influence and collaborate with fans, teams and other online users in the context of delivering products, knowledge, ideas, values and other content via the internet, so as to continuously construct and realize the goal and vision of orderly and healthy development of cyberspace, and to promote the professional development of internet celebrities and the standardization of netizens' words and deeds." The connotation of internet celebrity leadership emphasizes six aspects: emphasis on the context of cyberspace, emphasis on the personal traits of internet celebrities, emphasis on the leading and influencing roles of internet celebrities, emphasis on

interaction and collaboration with fans, teams and online users, emphasis on the continuous and dynamic construction and realization of the goal and vision of orderly and healthy cyberspace development, and emphasis on outcomes such as the professional development of internet celebrities and the standardization of netizens' behavior.

#### **4. Dimension Construction of Internet Celebrity Leadership**

Based on the CPM leadership theory, the dimensions of internet celebrity leadership mainly include character and morals leadership, performance achievement leadership, and maintenance leadership, among which character and morals leadership and maintenance leadership are the key competencies that internet celebrities should possess to act as leaders and perform their functions, while performance achievement leadership is a necessary capability for the daily work of internet celebrities.

##### *4.1 Character and Morals Leadership*

Character and morals leadership refers to the ability of internet celebrities to achieve self-awareness and self-education through the attention to and cultivation of their personal moral character, thereby establishing correct values and realizing effective leadership in cyberspace. Amid the evolution of the network society, many internet celebrities have gained rapid popularity due to their outstanding personal moral character, such as Li Ziqi who promotes traditional Chinese culture, Ding Zhen who presents a sincere and unpretentious image, and Dong Yuhui who pursues a practical and upright attitude; they convey positive energy to the public through their excellent moral character and exert a positive guiding role in both virtual and real societies. However, there are also cases of failure due to moral deficiency, such as Wei Ya stepping down from her influential position due to tax evasion and Li Jiaqi losing public favor for ridiculing and belittling consumers, which indicates that personal moral character is an indispensable and crucial factor in internet celebrity leadership. Therefore, internet celebrities should actively cultivate and demonstrate good moral qualities such as honesty, appropriate words and deeds, and social responsibility, and exert a positive guiding effect on followers, thereby enhancing their leadership in the network society, which is of great significance for maintaining a healthy online environment.

##### *4.2 Performance Achievement Leadership*

Performance achievement leadership refers to the ability of internet celebrities to effectively manage operational processes and allocate resources in online leadership activities, select accurate content, effective communication methods and evaluation approaches, and promote the smooth progress of work to ensure the accomplishment of goals. Most contemporary internet celebrities are originally motivated by certain commercial purposes, and once they gain a certain level of popularity, they possess the potential to convert their influence into economic value, bringing considerable benefits to themselves and their teams. Under the leadership of internet celebrities, this series of performance links is closely linked to traffic and fan bases. In the initial stage, internet celebrities usually create their own labels, or "personas", to improve their identity recognition in the vast data network, so as to attract

traffic and generate substantial economic returns [26]. Nevertheless, maintaining long-term popularity does not merely rely on personal symbols; the key lies in content production. Content is the core of interaction between internet celebrities and fans as well as the embodiment of value, so creating high-quality, attractive content that aligns with the interests of the audience is crucial to expanding influence. In the era when traffic is paramount, internet celebrities also need to comprehensively weigh a series of indicators such as the number of followers, comments, likes, reposts, and downloads to further increase traffic volume, expanding their influence in a “snowball” manner and thus becoming influential KOLs [27]. It can be seen that the operation mechanism of internet celebrities can be regarded as relying on content, taking individuals as symbols, using traffic as a criterion, and taking monetization as the ultimate goal to finally achieve performance objectives.

#### *4.3 Maintenance Leadership*

Maintenance leadership refers to the ability of internet celebrities to establish and maintain a harmonious and pleasant atmosphere with teams, fan groups and others through their own words, emotions and behaviors on the basis of equal, friendly and compatible relationships, so as to ensure the sustained stability and sound development of mutual relationships, namely the ability to effectively handle interpersonal relationships. Behind the leadership of internet celebrities, there is generally a team with clear division of labor and efficient collaboration. In such teams, internet celebrities focus on content creation and fan interaction, while behind-the-scenes workers provide support including content planning, publicity and promotion, fan management, and agency services. Therefore, interpersonal relationships and task collaboration among team members need to be built on the basis of friendliness and interdependence to maintain the normal operation of the team and ensure the achievement of team goals. In addition, internet celebrities also need to carefully maintain close ties with fan groups. In the process of self-presentation, internet celebrities need to frequently express the appeals of the audience, reflect their dissatisfaction, fulfill their wishes, and provide comfort and guidance for the audience in the fragmented and pan-entertainment spiritual wasteland [28]. In this process, internet celebrities should also adopt a public-friendly behavioral style to narrow the distance with the audience, thereby enabling the audience to develop a strong sense of identity and belonging [29]. To better manage fans, most internet celebrities also need to implement grouped management of fans; within the groups, internet celebrities establish trust relationships among users through joint participation in activities and information sharing to realize effective interaction among fans, thereby enhancing their social influence [28].

## **5. Development of an Internet Celebrity Leadership Scale Based on CPM Theory**

### *5.1 Item Collection for the Scale*

According to the CPM Leadership Behavior Scale developed by Ling Wenquan in 1987, it mainly focuses on leadership from “superior to subordinate” at the organizational level. Based on the previous analysis of internet celebrity leadership, this study argues that there are significant differences between

the operating model of internet celebrity leadership and traditional leadership, in that there is no clear superior-subordinate distinction in internet celebrity leadership. Given this characteristic, research on internet celebrity leadership should also take into account netizens' perceptions and feedback toward internet celebrities. Therefore, the development of an internet celebrity leadership scale cannot simply replicate the framework of the CPM Scale; instead, it is necessary to creatively construct a measurement scale that reflects internet celebrity leadership by incorporating the unique attributes of internet celebrities. In accordance with the previous dimensional analysis of internet celebrity leadership and with reference to the CPM Leadership Scale by Ling Wenquan et al., the initial CPM-based internet celebrity leadership scale was obtained through processing and refining the items, as shown in Table 1.

**Table 1. Initial CPM Scale of Internet Celebrity Leadership**

Latent variables	Observed variables
C(Character and morals leadership)	(C1)This internet celebrity is broad-minded and refrains from retaliation.
	(C2)This internet celebrity respects diversity and advocates consensus.
	(C3)This internet celebrity appoints people on merit and conducts with integrity.
	(C4)This internet celebrity is diligent and dedicated.
	(C5)This internet celebrity is impartial and incorruptible, placing public and collective interests above personal interests.
	(C6)This internet celebrity is honest and trustworthy, without fraud or deception.
	(C7)This internet celebrity behaves appropriately in words and deeds.
	(C8)This internet celebrity adheres to moral principles.
	(C9)This internet celebrity actively undertakes social responsibilities.
P (Performance achievement leadership)	(P1)This internet celebrity has proposed highly creative ideas and plans.
	(P2)This internet celebrity makes decisive decisions and dares to take responsibility.
	(P3)This internet celebrity has a clear understanding of its persona and goals.
	(P4)This internet celebrity ensures the output of high-quality content.
	(P5)This internet celebrity grasps various indicators of target progress, such as click-through rate and number of followers.
	(P6)This internet celebrity can adopt flexible measures in response to changing circumstances.
	(P7)This internet celebrity strictly controls task progress and completes target tasks on time.
	(P8)This internet celebrity helps and guides those with difficulties in work.
M(Maintenance)	(M1)This internet celebrity can evaluate others' work outcomes objectively.

---

leadership)	(M2)This internet celebrity does not inappropriately blame or complain about others.
	(M3)This internet celebrity can understand others' difficulties.
	(M4)This internet celebrity treats others equally.
	(M5)This internet celebrity actively encourages and supports others' work.
	(M6)This internet celebrity demonstrates empathy with the group.
	(M7)This internet celebrity exhibits people-friendly behaviors.
	(M8)This internet celebrity adheres to the principle of two-way interactive communication.

---

### *5.2 Pilot Test and Reliability Analysis*

A pilot test was first conducted using the initial questionnaire on a small scale, and SPSS 26.0 was employed to examine the reliability of the scale and perform exploratory factor analysis to refine the measurement items. The questionnaire was designed using a 5-point Likert scale, where 1 stands for strongly disagree, 2 for disagree, 3 for neutral, 4 for agree, and 5 for strongly agree. A total of 85 individuals were randomly selected on the rednote platform to distribute the questionnaire, and 85 questionnaires were recovered, among which 81 were valid.

This study used Cronbach's alpha coefficient to evaluate the reliability of the data, with a minimum threshold set at 0.70. When screening the measurement items, the corrected item-total correlation was required to be no less than 0.50, and the correlation coefficient between each pair of measurement items was required to be no less than 0.20 [30]. According to the above criteria, three measurement items were deleted: "(C3)Appoints people on merit and conducts with integrity", "(P1)Proposed highly creative ideas and plans", and "(P5)Able to grasp various indicators of target progress, such as click-through rate and number of fans".

On this basis, exploratory factor analysis was performed; using the criterion that eigenvalues are greater than 1.00, the principal component analysis method was adopted to extract factors, the varimax method was used for orthogonal rotation, and the factor loading of each measurement item was required to be no less than 0.50, cross-loadings no more than 0.40, and the correlation between factors under the same dimension no less than 0.30 [30]. In accordance with the above requirements, the measurement items "(C4)Diligent and dedicated" and "(P8)Willing to help and guide those with difficulties in work" were removed. The final Cronbach's alpha coefficient was 0.940, which is higher than 0.70.

Factors were extracted according to the criterion of eigenvalues greater than 1, and the results showed that three factors could be extracted, with a total explained variance of 65.723%. The KMO value was 0.897, the observed value of Bartlett's test of sphericity was 1103.655, and the probability p was close to 0.00, which is lower than the significance level of 0.05, indicating that the data are suitable for factor analysis. Verified by exploratory factor analysis, a final scale consisting of 20 measurement items was

formed, as shown in Table 2.

**Table 2. Exploratory Factor Analysis**

Items	Factors			Variance explained	Cumulative variance explained	Cronbach's alpha
	1	2	3			
M1	0.688					
M2	0.799					
M3	0.782					
M4	0.707			26.849%	26.849%	0.922
M5	0.760					
M6	0.732					
M7	0.746					
M8	0.750					
C1		0.768				
C2		0.719				
C5		0.799				
C6		0.827		23.168%	50.018%	0.923
C7		0.651				
C8		0.850				
C9		0.574				
P2			0.730			
P3			0.650			
P4			0.798	15.706%	65.723%	0.809
P6			0.740			
P7			0.581			

### 5.3 Validity Test of the Scale

#### 5.3.1 Data Collection and Sample Profile

The questionnaire consisted of two parts: the first part covered the basic information of respondents, including gender, age, and relationship with the evaluated internet celebrity; the second part contained information on observed variables, with a total of 20 measurement items. For this study, the sample was required to meet the following criteria: first, high internet usage frequency and familiarity with internet celebrities; second, a certain level of social media engagement or attention to internet celebrities. Considering the eligibility criteria and accessibility, the questionnaire was mainly distributed to rednote users, a group with a large population size, sufficient knowledge of the internet and internet celebrities, and relatively active attention to internet celebrity dynamics, thus possessing

adequate representativeness. In this study, questionnaires were randomly distributed online to rednote users, yielding a total of 230 responses; after excluding 8 invalid samples (questionnaires with response time beyond the specified range and random selection), 222 valid samples were obtained, and the sample size met the statistical requirement of being 5 to 10 times the number of scale items. Among the samples, 103 were male (46%) and 119 were female (54%); 91 were under 22 years old (41%), 78 were aged 23–35 (35%), 28 were aged 36–45 (13%), and 25 were over 46 years old (11%); 75 were team members or colleagues (34%), 74 were fans (34%), and 72 were ordinary netizens (32%).

### 5.3.2 Reliability Test of the Scale

The Cronbach's alpha coefficients of the personal moral dimension, performance achievement dimension, and group maintenance dimension of internet celebrity leadership were 0.916, 0.839, and 0.914, respectively, all of which were higher than 0.7, indicating satisfactory internal consistency of the scale with no need for further item deletion. The overall alpha value was 0.942, the KMO value was 0.933, and the total explained variance was 64.763%, suggesting high overall reliability and suitability for confirmatory factor analysis.

### 5.3.3 Validity Test

AMOS software was used to evaluate the dimensions of the constructed framework. Table 3 presents the standardized factor loadings, composite reliability (CR), and average variance extracted (AVE) of the observed variables. Based on the criteria of standardized factor loadings greater than 0.5, CR greater than 0.6, and AVE greater than 0.5, all indicators of the observed variables clearly met the requirements, indicating that the scale possessed satisfactory convergent validity.

**Table 3. Standardized Factor Loadings, CR and AVE of Observed Variables**

Latent variables	Observed variables	Standardized loadings	factor P	CR	AVE			
C(Character and morals leadership)	C1	0.810	***	0.918	0.615			
	C2	0.705	***					
	C5	0.772	***					
	C6	0.818	***					
	C7	0.782	***					
	C8	0.86	***					
	C9	0.73	***					
	P (Performance achievement leadership)	P2	0.697			***	0.842	0.518
		P3	0.756			***		
P4		0.665	***					
P6		0.807	***					
P7		0.661	***					

	M1	0.737	***		
	M2	0.749	***		
	M3	0.819	***		
M(Maintenance leadership)	M4	0.756	***	0.915	0.573
	M5	0.765	***		
	M6	0.736	***		
	M7	0.762	***		
	M8	0.729	***		

The method of comparing the square root of AVE with the correlation coefficients among latent variables was adopted, and Table 4 presents the magnitude relationship between AVE and the correlation coefficients. The square root values of AVE for each latent variable are all greater than the correlation coefficients with other variables, indicating that group maintenance, performance achievement, and personal moral character possess satisfactory discriminant validity.

**Table 4. Analysis of Discriminant Validity Results**

	M	P	C
M	(0.757)		
P	0.65	(0.72)	
C	0.709	0.642	(0.784)

*Note.* The values in parentheses in the diagonal cells of the table are the square roots of AVE for the corresponding latent variables, and the values in other cells are the correlation coefficients between variables.

#### 5.3.4 Model Fit and Evaluation

Model estimation was conducted using AMOS software, and model fit was evaluated using model fit indices, including absolute fit indices, incremental fit indices, and comparative fit indices. Figure 1 presents the model results, and Table 5 shows the calculated index values; the results indicate that all fit indices meet the required criteria, suggesting that the CPM factor model of internet celebrity leadership fits the survey data well.

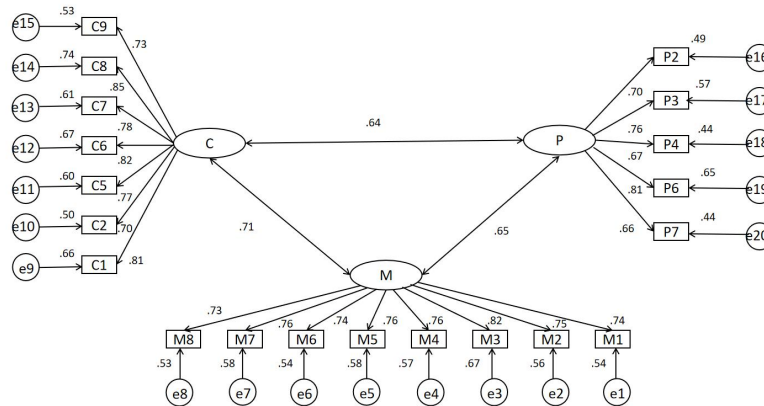

Figure 1. Plot of Parameter Estimation Results

Table 5. Model Fit Indices

Fit index	Recommended fit value	Empirical value	Judgment of fit
CMIN/DF	<3	2.351	Yes
RMR	<0.05	0.042	Yes
RMSEA	<0.08	0.078	Yes
CFI	>0.9	0.918	Yes
IFI	>0.9	0.919	Yes
TLI	>0.9	0.907	Yes

6. Conclusions and Discussion

6.1 Research Conclusions

First, internet celebrity leadership refers to the ability of internet celebrities to leverage their distinctive traits to lead, influence and collaborate with fans, teams and other online users in the context of delivering products, knowledge, ideas, values and other content via the internet, so as to continuously construct and realize the goal and vision of orderly and healthy development of cyberspace, and to promote the professional development of internet celebrities and the standardization of netizens' words and deeds. Compared with previous research findings, the conceptual connotation of internet celebrity leadership discussed in this study shares several similarities: first, both emphasize the importance of informal leadership; second, both include influence. However, there are also differences: first, this study identifies the goal orientation of internet celebrity leadership, namely leading cyberspace toward healthy and orderly development, and as influential public figures, internet celebrities undeniably undertake an important mission of fulfilling specific responsibilities while enjoying social attention and resources; second, this study highlights the leadership capability of internet celebrities, meaning internet celebrity leadership is not merely their influence over others, but also the ability to lead netizens to continuously build and achieve the vision of orderly and healthy cyberspace, which is

reflected both in leading the standardization of online behaviors and in the self-leadership of internet celebrities' own professional development.

Second, internet celebrity leadership consists of three factors: character and morals leadership, performance achievement leadership, and maintenance leadership, which differ qualitatively in terms of connotative depth, value embodiment and functional role. Character and morals leadership refers to internet celebrities' ability to manage their own moral cultivation and is the primary step for internet celebrities to exert leadership, which is consistent with the view of Li Ming et al. that personal moral character exerts the strongest influence among various factors of leadership behavior [19]. Performance achievement leadership refers to internet celebrities' work ability to accomplish goals, providing necessary support for them to enhance leadership. This type of leadership differs from that in traditional organizations, mainly in the core mechanism of performance realization, namely that internet celebrities achieve performance by satisfying the needs of netizens as followers, so all their work activities revolve around netizens, which has also been confirmed by most scholars. Maintenance leadership refers to internet celebrities' ability to handle interpersonal relationships and is the key for them to exert leadership and obtain sustainable support. Internet celebrities need to cultivate both internal competence and external image; maintaining good relationships with internal team members ensures high-quality content production and operation, while maintaining positive relations with external fan groups secures continuous support and participation.

Third, integrating the CPM leadership theory with the functions and attributes of internet celebrities, this study constructs an internet celebrity leadership scale composed of 3 latent variables and 20 observed variables. The test results show that the scale has satisfactory internal consistency reliability, composite reliability, convergent validity and discriminant validity, and possesses certain explanatory power for internet celebrity leadership. In the measurement model, a higher factor loading indicates that the observed variable can better reflect the characteristics of the latent variable [31]. Among the 7 observed variables of character and morals leadership, "This internet celebrity is broad-minded and never retaliates" (0.810), "This internet celebrity is honest and trustworthy without fraud" (0.816), and "This internet celebrity adheres to moral principles" (0.86) carry relatively large weights with factor loadings all above 0.8, and the remaining factor loadings are above 0.7, sufficiently indicating that internet celebrities exhibit strong leadership in the C dimension. Among the 5 observed variables of performance achievement leadership, "This internet celebrity can take flexible measures in response to changing situations" (0.807) carries the largest weight and well reflects performance-oriented leadership, while other indicators range from 0.6 to 0.8, suggesting that internet celebrities' leadership in the P dimension is moderate. Among the 8 observed variables of maintenance leadership, "This internet celebrity can understand others' difficulties" (0.819) carries the largest weight, and the remaining factor loadings are all above 0.7, indicating that internet celebrities' leadership in the M dimension is favorable.

## 6.2 Research Limitations and Prospects

This study has the following limitations: first, restricted by sample size and scope, the generalizability of the research remains to be verified; therefore, future research can further expand the scope of data collection to better improve the universality of the conclusions. Second, the CPM theory is only a subset of the multidimensional structure of leadership, and the internet celebrity leadership scale developed based on CPM dimension division has limitations and cannot assess the overall leadership of internet celebrities. Accordingly, future studies should continue to explore and integrate other leadership dimensions such as online media leadership. As internet celebrity leadership emerges, strengthens and evolves with the internet, it is particularly important to examine internet celebrity leadership from the perspective of online media leadership to make the evaluation system more comprehensive and systematic. Third, this study only explores the concept, dimensional structure and scale evaluation system of internet celebrity leadership; future research can conduct in-depth investigations into the application of internet celebrity leadership, such as analyzing its impacts on public values and lifestyles.

## Reference

- [1] Li Liwen. The Implementation Mechanism of Non-Power Leadership: An Analysis Based on Online Opinion Leaders[J]. *Journal of Tianjin Administration Institute*, 2015, 17(03): 91-97.
- [2] Al-Emadi F.A, Ben Yahia I. Ordinary Celebrities Related Criteria to Harvest Fame and Influence on Social Media[J]. *Journal of Research in Interactive Marketing*, 2020, 14(2): 195-213.
- [3] Xu Jialin, Hou Shaoxun. The Dual Impacts of “Internet Celebrities” on Young People’s Value Choices[J]. *Jiang-huai Tribune*, 2020, (01): 124-129.
- [4] Wang Weibing. The Generation Logic, Ethical Reflections and Regulatory Guidance of the Internet Celebrity Economy[J]. *Truth Seeking*, 2016, (08): 43-49.
- [5] Zhong Xiaoping, Wang Jingjing, Yu Xiaohua. Internet Celebrities, Public Opinions and Food System Change in China: a New Conceptual Framework[J]. *International Food and Agribusiness Management Review*, 2023, 26(3): 467-487.
- [6] Tran G, Yazdanparas A, Strutton D. Investigating the Marketing Impact of Consumers’ Connectedness to Celebrity Endorsers[J]. *Psychology & Marketing*, 2019, 36(10): 923-935.
- [7] Chen Ting, Jaeyeon S. Influence of Internet Celebrity’s Characteristic on Consumer Purchase Intention: The Mediating Effect of Self-Construct[J]. *Korean Management Consulting Review*, 2021, 21(4): 159-170.
- [8] Fan Zengmin, Lu Jian, Wang Likun. Consumption-Driving Factors and Model Innovation of New Retail under the Boom of Social Internet Celebrity E-Commerce[J]. *Journal of Commercial Economics*, 2021, (08): 42-44.
- [9] Liu Tingting, Xu Deya. Xiaohongshu Emerging as a Fashion Cultural Infrastructure and Reshaping Fashion Ideals: A Qualitative Research of Three Types of Fashion Bloggers[J].

- Chinese Journal of Journalism & Commun, 2023, 45(06): 59-80.
- [10] Chai Baoyong, Li Zilin. The Theoretical Origins of Leadership and the Theoretical Observation of the Leadership of the Communist Party of China[J]. Journal of Manag, 2021, 37(08): 11-20.
- [11] Maxwell J.C. The 21 Irrefutable Laws of Leadership[M]. Beijing: China Youth Press, 2012.
- [12] Bennis W, Nanus B. Leaders[M]. Zhejiang: Zhejiang People's Publishing House, 2016.
- [13] Miao Jianming, Huo Guoqing, Meng Jianping. A Study on the Five-Force Model of Leadership[J]. Leadership Science, 2006(9): 20-23.
- [14] Liu Yibing, Fu Guangkuai. On the Innovation of Institution and Mechanism in the Integrative Development of Teacher Education[J]. Educational Research, 2014(1): 111-116.
- [15] Joyce W. Organizational Change[M]. Beijing: Posts & Telecom Press, 2003.
- [16] Zhou Min. Probe and Reflections on the Leadership from the Perspective of Chinese Modernization[J]. Leadership Science, 2024, (02): 21-27.
- [17] An Fengjun. Exploration on the Model and Methods for Evaluating Leadership[J]. Leadership Science, 2024, (05): 43-47.
- [18] Li Ming, Ling Wenquan. Study on Chinese indigenous leadership:Exploration and enlightenment of CPM leadership theory[J]. Psychological Research, 2023, 16(05): 449-455.
- [19] Li Ming, Ling Wenquan, Liu Shishun. A Scenario Simulation Experimental Study on the Dynamic Mechanisms of CPM Leadership Factors[J]. Nankai Business Review, 2013, 16(02): 16-25.
- [20] Xue Shen, Nie Hui. The Generative Logic and the Guidance of Online Star Phenomenon[J]. Academic Journal of Zhongzhou, 2017, (04): 163-168.
- [21] Ji Yaping, Li Chenglin. The Occurrence Logic, Risk Review and Regulation Path of the "Internet Celebrity Public Officials" Phenomenon[J]. Leadership Science, 2023, (06): 19-25.
- [22] Zhao Xiqun, Chen Xiaodan. The Generation and Evolution Mechanism, Value Inquiry and Governance Path of Internet Celebrity Culture[J]. Journal of Xiangtan University(Philosophy and Social Sciences), 2023, 47(01): 133-141.
- [23] People's Daily Online. Society Needs Positive Energy "Internet Celebrities"[EB/OL].Availablefrom:  
<http://industry.people.com.cn/n1/2020/0616/c413883-31748092.html>[Accessed 19th June 2025]
- [24] Li Congyu, Xin Xiangyang. Omnimedia Development and Prevention and Control of Ideological Security Risks in Cyberspace[J]. People's Tribune, 2024, (12): 74-76.
- [25] Zhang Jie. The Development Path of "Mainstream Internet Celebrities" from the Perspective of @Youth League Committee of China[J]. Media, 2018, (02): 56-57.
- [26] Lin Gang, Yao Meng. Construction, Interpretation and Collapse of Internet Celebrity's "Persona" from the Perspective of Pragmatic Identity Theory[J]. Media Observer, 2022, (01): 36-43.
- [27] Chai Xiuqing. Driving Factors, Ecological Layout and Development Trends of Social Internet Celebrity E-Commerce[J]. Journal of Commercial Economics, 2024, (05): 76-79.

- [28] Wang Xuejian, Feng Ruizhi."Enlightenment of the "Internet Celebrity" Phenomenon on Ideological and Political Theory Courses in Colleges and Universities[J]. *The Party Building and Ideological Education in Schools*, 2017, (05): 42-46.
- [29] Chun Chao. Home Fitness Trend and Marketing Strategies of Fitness Brands in the New Media Era—Based on the Analysis of Liu Genghong Phenomenon[J]. *Sports & Science*, 2022, 43(05): 19-25.
- [30] Zhang Hao, Dong Zhiqi, Wang Hongsu. The Influence of Value Co-Creating on Fashion Design Attributes:Scale Development and Empirical Study[J]. *Chinese Journal of Management*, 2017, 14(09): 1351-1361.
- [31] Wan Liyong, Du Jing, Shu Ai. An Empirical Study on Factors Influencing Quality Satisfaction of Educational UGC—Based on an Extension of ACSI Model[J]. *China Educational Technology*, 2019, (03): 72-80.